

SigTEL (1 to 16 Lines) Standalone EVCS - Quick Start Installation Guide

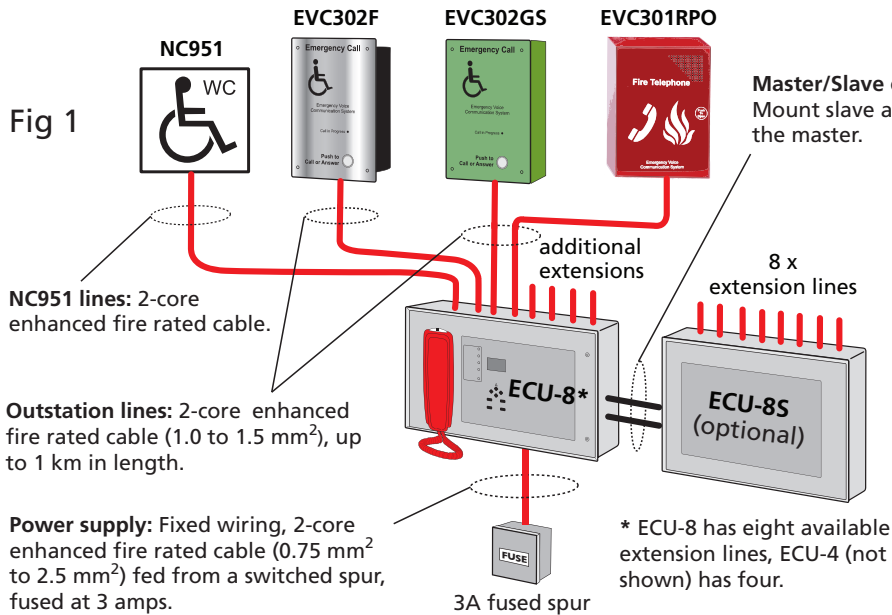

THIS GUIDE IS ONLY FOR EXPERIENCED INSTALLERS OF EMERGENCY VOICE COMMUNICATION SYSTEMS (EVCS) and summarises key information provided in the full manual (Document No. DAU0000091). Section numbers, e.g. **6.1**, reference sections in the full manual with additional information.

SigTEL EVCS Typical Wiring Overview



SigTEL EVCS Components	
Part No.	Description
ECU-4	4 Line Master EVC Controller c/w handset & display, needs 2 x 7 Ah batteries
ECU-8	8 Line Master EVC Controller c/w handset & display, needs 2 x 7 Ah batteries
ECU-8NT	8 Line Master EVC Controller (no handset) c/w display, needs 2 x 7 Ah batteries
ECU-8S	8 Line Slave EVC Expansion Unit (adds 8 extra lines to ECU-4, ECU-8, ECU-8NT)
EVC302F/GF	Disabled Refuge (Type B) Outstation, flush mounting, SS ('G' - Green steel)
EVC302S/GS	Disabled Refuge (Type B) Outstation, surface mounting, SS ('G' - Green steel)
EVC301RPO	Red Fire Telephone (Type A) Outstation c/w handset (push to open)
EVC301RLK	Red Fire Telephone (Type A) Outstation c/w handset (lift lock)
BF359/1	Weatherproof enclosure for EVC302F/GF
BF359/3D	Stainless steel enclosure for ECU-4/ECU-8/ECU-8NT
NC951	Disabled Persons Toilet Alarm (DPTA)
FITT	EVC Line Tester
BC286/2	24 V, 7 Ah battery (2 x 12 V) used with ECU-4/ECU-8/ECU-8NT
AFP385	Grey flush bezel for ECU-4/ECU-8/ECU-8NT
T-BEZ301	Red flush bezel for EVC301RPO and EVC301RLK
ECU423	PC programming software

Install the EVCS

Location **6.1**

Site all equipment indoors in well-lit areas, free from obstruction. If background noise exceeds 40 dBA, use an acoustic hood. Site control unit(s) in the control room or lobby, 1.4 metres above final floor level (FFL). Fit Type A (fire telephone) outstations in fire fighting lobbies and fire access points, 1.3 to 1.4 metres above FFL. Fit type B (disabled refuge) outstations in disabled refuges, 0.9 to 1.0 metre above FFL.

Mounting **7**

Remove base PCBs before first fix installation to protect them and expose the base mounting holes. Wall mount the control units, either surface or semi-flush. Fix the base securely onto a wall using No.8 round-head, or countersunk screws. If an optional ECU-8S is fitted make the interconnections to the ECU-4/ECU-8 using supplied looms and short length of steel conduit (25 mm OD, max. length 60 mm). After mounting, remove any dust/swarf and re-install base PCBs. Ensure all connecting looms are refitted.

Wiring and Cable Entry **4**

See Fig 1 above for cable types. Install wiring in accordance with the relevant national, regional or local regulations (in the UK this is the IEE Wiring Regs BS 7671 and BS 5839 Part 1). Use enhanced fire-rated cables from the controller to the outstations / NC951 and the power supply.

Test Extension Lines **12**

Test all lines for faults before terminating extension lines to the control unit. Also, test outstation lines using a FITT EVC line tester (see component list above).

CAUTION: DO NOT use an Insulation Resistance Tester with any devices connected as they will be destroyed and the warranty will be void.

Fit Outstations & NC951 Interface **11**

Maximum recommended cable distance to the outstations is 1 km, beyond which audio quality may degrade. For wiring and connection details refer to Type A outstation instructions (Doc. No. DCM0003819) and Type B outstation instructions (Doc. No. DAU0302000).

Connect Extension Lines to the Control Equipment **13.1**

Do not connect extension lines to the ECU-4/ECU-8, or optional ECU-8S, until they have been tested, fault-free and suitable cable glands fitted. Connect extension lines directly to the Exchange PCB (see Fig 2 left). Connect screens to the earth terminal in the back of the enclosure.

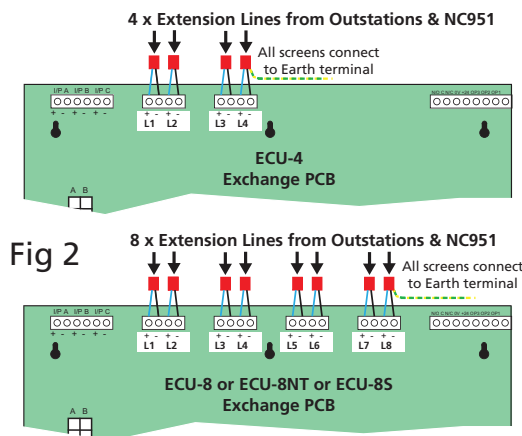

Connecting Mains 10 and Batteries 16

See Fig 1 overleaf for mains cable type. Connect a suitable 230 Vac supply to the ECU-4/ECU-8 via the base knockouts. Terminate the mains cable at the Power Supply PCB (plug P2) and NOT to main earth chassis (see Fig 3, right).

For the emergency standby power supply, only use good quality, sealed VRLA batteries. Position and connect two 12 V, 7 Ah batteries (BC286/2) to the ECU-4/ECU-8 using the supplied battery connection leads (see Fig 4, far right).

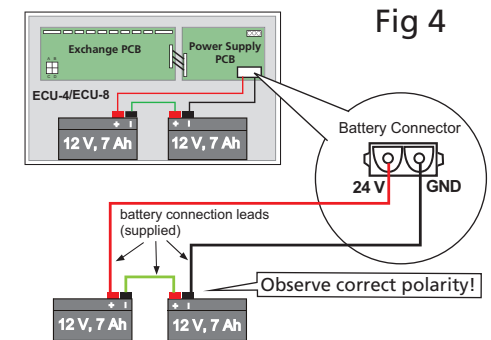
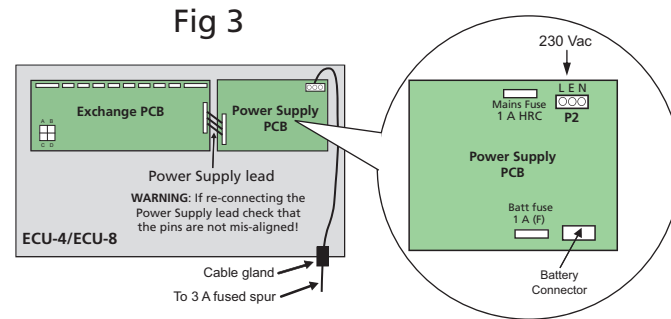

Commission the EVCS

Before commissioning the system ensure that all equipment is fully installed, connected and wiring tested. Check all handsets are on-hook and no calls or faults are present on the system. The ECU-4/ECU-8 shows 'System Healthy' status at its LCD display. Configure the system by following the flow chart below.



HINT!

PC Tools (ECU423) are available that allow quick and easy editing of extension names and also provide limited engineering functions. Contact your supplier for details.

Configure the system 17.1

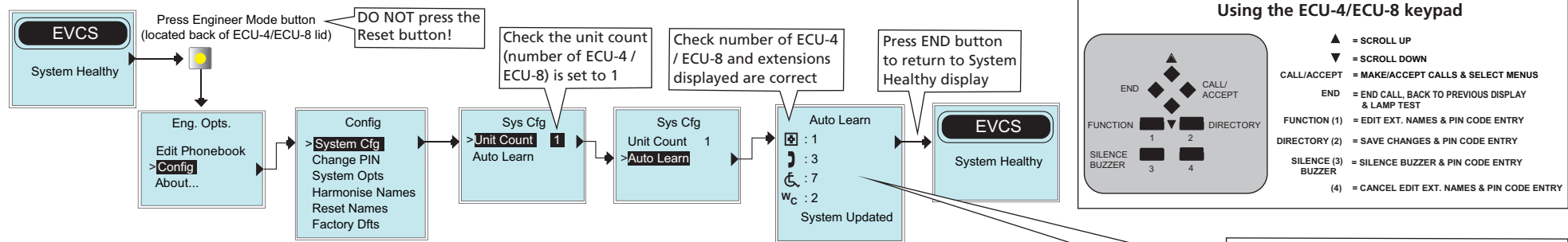

Check audio quality and interactively name extensions 17.5

At the ECU-4/ECU-8, with the handset on-hook, select the 'Edit Phonebook' option by following the flow chart below. With an operator at the ECU-4/ECU-8, go to each outstation in turn and make a call. At the ECU-4/ECU-8 lift the handset and press the ACCEPT button. The outstation's channel is opened for speech and automatically selected for editing. Check audio quality of the line and inform the operator at the ECU-4/ECU-8 your position. They can edit the outstation name directly (see Naming Extensions below). Repeat this process for all remaining outstations but to avoid confusion only call in from one outstation at a time. Outstations can also be manually named if you are sure of its location.

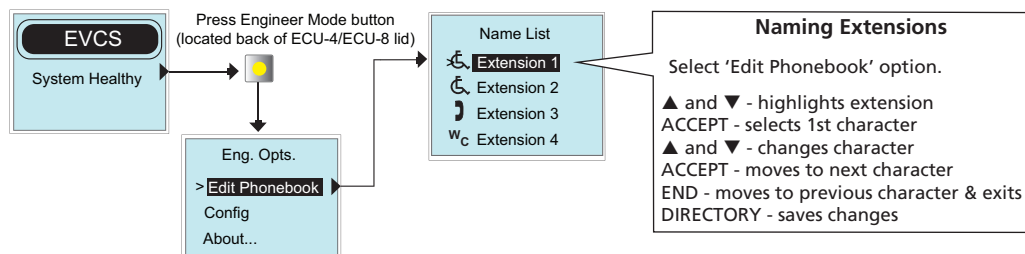
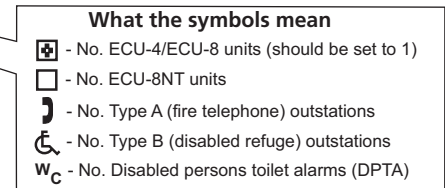

Additional System Set up Features

Add/Remove Outstations & DPTA 17.3

Clear Recent Calls 18.4

Change Security PIN Code 18.1

Set up Auto-Answer 18.5

Set up Latch Faults 18.3

©Errors and omissions excepted. No responsibility can be accepted by the manufacturer or distributors of this product for any misinterpretation of this instruction, or for the compliance of the system as a whole. The manufacturer's policy is one of continuous improvement and we reserve the right to make changes to product specifications at our discretion and without prior notice.