

**204-0003 Twinflex Multipoint ASD Detector,
204-0001 Twinflex Multipoint ASD with Sounder,
204-0012 Twinflex Multipoint ASD with Sounder / Strobe**

General Description

The Twinflex Multipoint ASD is a plug-in type smoke detector that utilises a photo-electric sensing chamber to make a measurement corresponding to smoke density. The device also incorporates a thermistor sensing circuit to allow for accurate heat measurement. These elements allow the device to be configured to a smoke, heat or combined setting. This device is only compatible with the Twinflex control panels (and their associated detection and alarm equipment) and may also incorporate a sounder beacon (ignore all references to sounders/beacons if your device has no sounder/beacon).

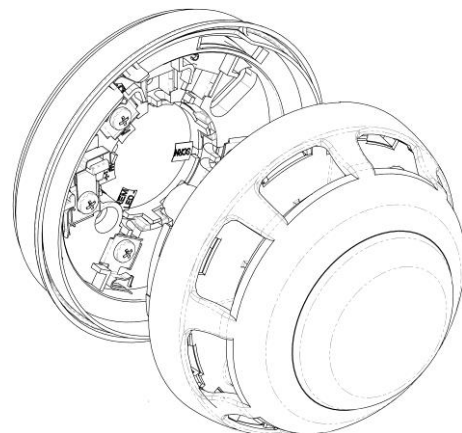

Before Installation

The detector must be installed in compliance with the control panel installation manual. The installation must also meet the requirements of any local authority. For maximum performance the detector should be installed in compliance with BS5839-1:2013.

Spacing

Fike recommends spacing detectors in accordance with BS5839-1:2013. Due to the effects of IR and possible magnetic interference, detectors should not be fitted any closer than 500mm (preferably 1000mm) to a light fitting or any other source of IR or EMI. In addition to this recommendation the device should be mounted so that the indication LED is facing towards the light fitting. For more specific information regarding detector spacing, placement and special applications please refer to BS5839-1:2013.

Note: As with other optical detectors, this device should not be located where subjected to high levels or pulses of light or infra red light, as this may cause false alarms or faults.

Detector Installation

All wiring must be installed in compliance with the recommendations laid out by BS5839-1:2013 as well as any special recommendations documented in the control panel installation manual. The cabling used should be of a 2-core 1.5mm² screened, fire resistant type (e.g. FP200 equivalent), and is to be wired in the form of a screened 2-core radial circuit (with no spurs) from the control panel, terminating at the last ("End of Line") device.

Fix the detector base in a suitable horizontal position using the two screw slots provided, remembering to allow enough cable length for termination. You may then terminate your cables directly into the terminal block according to the terminal labels. It is important to maintain the screen continuity in order to protect against data corruption from interference.

Connections

| | Terminal | Description |
|------|-----------------|------------------------------------|
| 1 | REM LED – | Remote LED 0V (-VE) |
| 2 | ZONE + | Zone In/Out +VE and Remote LED +VE |
| 3 | 0V | Zone In/Out 0V |
| 4 | Not Fitted | N/A |
| 5 | Not Fitted | N/A |
| SCRN | SCRN | Screen |

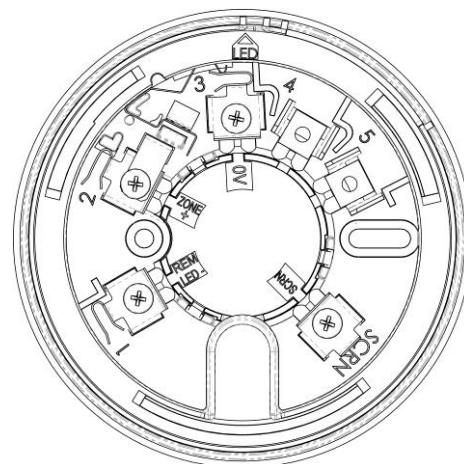

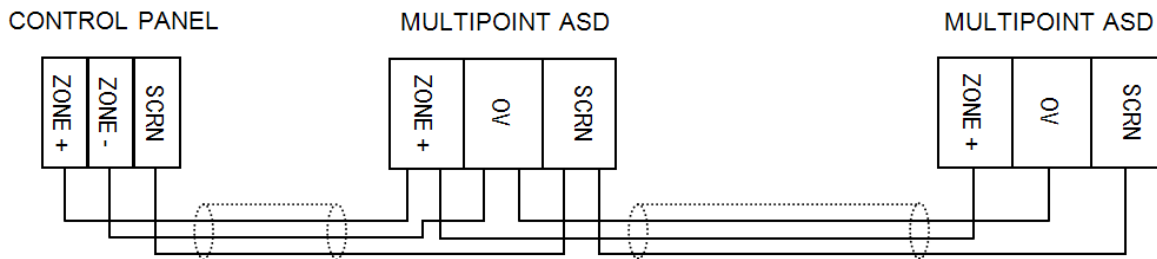

Twinflex Multipoint ASD Detectors can be mixed on the same zone as other types of Twinflex device (e.g. Twinflex Call-points and earlier detectors). If mixed with earlier detectors, the zone must be set to 'CP/DET' and not 'CP/SM/HT'. The above diagram shows how to make the zone positive, zone negative and screen connections between the control panel and Twinflex Multipoint ASD Detectors. Refer to the instruction leaflets supplied with other Twinflex devices for their equivalent wiring/terminal labelling details.

Please note that the SCRNM terminal on the detector bases should only be connected to the zone cable screen and NOT to the building earth. The cable screen is connected to earth at the panel end only, via the zone "SCRNM" terminal (or EARTH terminal on the Twinflex V3 2/4/8 Zone panels). It is important to maintain the screen continuity in order to protect against data corruption from interference.

Please remember that all high voltage testing must be carried out before the installation of the detector base or electronics, as this will cause damage (a small electronics module is also present in base). Once all testing has been carried out on the cabling and 'continuity & integrity' has been proven, the detection base & head may be fitted. Before fitting the detector head program the device settings via the on-board DIL switches, remembering to set the EOL for the last device.

Remember that the device at the end of the line must have its EOL signal activated using the relevant DIL switch. Do not use a resistor or capacitor (or another manufacturer's End of Line device) as the end of line, as this may prevent correct operation of the zone.

To install the detection head, locate the pins and gently twist until the unit locks in place.

Tamper Resistance and Head Removal

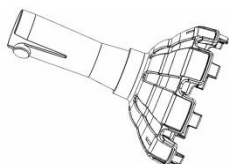

The ASD detector incorporates a tamper resistant locking mechanism that prevents its removal from the base without the use of a special tool. To remove the device, the tool should be attached over the detector and turned anti-clockwise allowing the detector to be removed from the base.

Remote Indicator

The remote LED terminals ('Remote LED + / -') may be used to connect a separate LED (Pt No. 600-0092). The LED functions are as follows:

- 5ms every 5 seconds: End of Line
- 5ms every 1.3 seconds: Fault
- 350ms every 0.7 seconds: Fire detected by detector
- Continuous: Fire detected by detector and processed at panel
- 100uS pulse every 20seconds in standby (2 pulses if set to heat)

Note that the LED does not require a resistor.

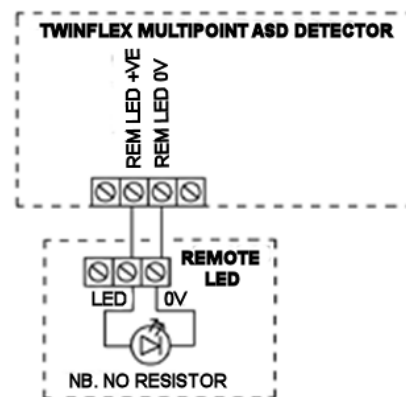

DIL Switch Settings

The detector DIL switches may be used to program the operation of the Multipoint ASD Detector. They may be altered when the device is removed from the base. If a heat detection mode is selected then use the 'HEAT' labels supplied to label the base of the detector clearly.

The last device on the circuit must have the EOL signal enabled (switch number 1 in the 'ON' position).

***If the Multipoint ASD Detector is used with the SRP panel, DIL switch 2 must be set in the OFF position, (Logical Link OFF). DIL switches 6 must be ON & 7 must be OFF, (for continuous sound pattern).**

The SRP panel controls the sound pattern so if the Multipoint ASD Detector is set to anything other than continuous sound it will conflict with the SRP panel.



| | | DIL SWITCH SETTINGS | | | | | | | |
|-----------------------|---|---------------------|-----|-----|-----|-----|-----|-----|-----|
| | | 1 | 2 | 3 | 4 | 5 | 6 | 7 | 8 |
| EOL Signal | Disabled (no end of line signal) | OFF | | | | | | | |
| | Enabled | ON | | | | | | | |
| Detection Mode | Disabled (no detection) | | | OFF | OFF | OFF | | | |
| | Smoke 1 – Standard optical with high thermal enhancement | | | ON | OFF | OFF | | | |
| | Smoke 2 – Standard optical with normal thermal enhancement | | | OFF | ON | OFF | | | |
| | Smoke 3** – Low sensitivity optical with transient rejection | | | ON | ON | OFF | | | |
| | Heat 1 – Rate of Rise 58°C, general use in normal, stable environments (Class A1) | | | ON | OFF | ON | | | |
| Logical Link * | Heat 2 – Low fixed 58°C, Domestic kitchens etc (Class A1) | | | OFF | ON | ON | | | |
| | Heat 3 – Hi Fixed 90°C, Commercial kitchens, boiler rooms (Class C) | | | ON | ON | ON | | | |
| | Smoke 2 / Heat 2 Combined | | | OFF | OFF | ON | | | |
| | Logical link disabled | | OFF | | | | | | |
| Sound Pattern | Logical link enabled | | ON | | | | | | |
| | Disabled (no sound) | | | | | | OFF | OFF | |
| | Sound 1 (Continuous tone at 970 Hz) | | | | | | ON | OFF | |
| | Sound 2 (Alternating tone at 800/970 Hz) | | | | | | OFF | ON | |
| Sounder vol | Sound 3 (Sweep up tone at 800 to 970 Hz) | | | | | | ON | ON | |
| | Low | | | | | | | | OFF |
| | High | | | | | | | | ON |

* For use with Twinflex Pro & Twinflex V3 Checkpoint Plus Control panels only. The setting will be ignored on older systems without Checkpoint Plus. With Logical Link enabled the sounder in that device only will operate during the Alarm Confirmation period, and with the Logical Link disabled all the sounders in the same zone as the device in alarm will operate during the Alarm Confirmation period.

** Not Approved to EN54-7.

Power Up

The Multipoint detector requires approximately one minute on power up to boot up its processor and settle down to normal operation. Do not test the detector during this time. Ensure that the Detector Head is already installed when the system is powered up otherwise a fault condition will be present.

Head Contamination Warnings

If a smoke detector becomes dusty, its operation is affected, either making it more prone to false alarms, or in rare cases reducing its sensitivity. The Multipoint LED will flash once approximately every 1.3 seconds. At the control panel (V3 panel), the common 'Fault' LED will flash, the buzzer will sound and the relevant 'Zone Fault' LED will flash at approximately twice the rate of the buzzer. On the Twinflex Pro panel, the common 'Fault' LED will be on, the buzzer will sound and the system indication 'zone LED will flash at approximately twice the rate of the buzzer. The display will indicate FAULT 00x OF 00x & Z0x: Zone description and fault type.

Replacing Contaminated Optical Chambers

The optical chamber within the detector is not user serviceable. When an optical chamber becomes contaminated we recommend replacing the detector. Cleaning an old chamber is not possible with this device as it is a sealed unit. It is essential that the location of the contaminated device is verified using the device LED which will flash once approximately every 1.3 seconds.

Beacon Operation (Not EN54-23 Compliant)

The Multipoint ASD may also incorporate a sounder or beacon (ignore all references to sounders / beacons if your device has no sounder / beacon). If the unit includes a Beacon this consists of a number of high output LEDs mounted beneath a diffusing lens at the lowest part of the detector.

The beacon will start to operate when the device receives a command to activate its sounder, even if the sound pattern is set to **SP0 - Sounder off**. Thus, it is possible for the beacon to provide a discrete warning by setting the sound pattern to SP0.

Testing

We recommend the use of suitable smoke test equipment such as the 'No Climb' SOLO 300 tester or an equivalent product. Due to the fact that the smoke detection modes are all 'thermally enhanced', it may be noticeable that on test the devices respond more slowly than may be expected. This is perfectly normal and is due to the fact that during test there is no additional heat present to cause the sensitivity to be enhanced.

Smoke mode 3 requires that the concentration of smoke is kept up for a longer period to trigger the device into alarm, so patience is required. Small regular applications of test smoke are best in order to avoid drenching the detector as this may result in sticky residues being left behind.

Technical Data

| | | |
|----------------------------|--|---|
| Dimensions | | 107mm diameter x 75mm |
| Operating temperature | | -10°C to +50°C |
| Operating Voltage Range | | 18V to 32V DC |
| Operating Current | Quiescent | 101 uA (Typical) |
| | End of line ON if applicable..... | +50 uA (Typical) |
| (no strobe version) | Alarm Sounding – Sounder High..... | 8.00 mA (Typical) |
| | Alarm Sounding – Sounder Low..... | 2.50 mA (Typical) |
| | Alarm Sounding – Sounder Off | 150 uA (Typical) |
| | Alarm Activated..... | 15.50 mA (Typical) |
| | <i>(in addition to Alarm Sounding)</i> | |
| (strobe version) | Alarm Sounding – Sounder High..... | 10.50 mA (Typical) |
| | Alarm Sounding – Sounder Low..... | 4.90 mA (Typical) |
| | Alarm Sounding – Sounder Off | 2.60 mA (Typical) |
| | Alarm Activated..... | 18.00 mA (Typical) |
| | <i>(in addition to Alarm Sounding)</i> | |
| LED Operation | Detector in Normal State (Smoke)..... | Flash at 20 second intervals |
| | Detector in Normal State (Heat) | Double flash at 20 second intervals |
| | Detector at EOL..... | Flash at 5 second intervals |
| | Detector in Fault | Flash at 1.3 second intervals |
| | Detector Detecting Fire | Flash at 0.7 second intervals |
| | Detector in Fire (once processed at panel) | Continuous |
| Loading Units | | V3 Panel: Pro Panel: |
| | Max Loading Units per zone | 27 SLU..... 160 DLU |
| (no strobe version) | Sounder High..... | 1.35 SLU..... 8.0 DLU |
| | Sounder Low | 1.125 SLU..... 6.5 DLU |
| | No Sounder | 0.5 SLU..... 1.0 DLU |
| (strobe version) | Sounder High..... | 2.7 SLU..... 16.0 DLU |
| | Sounder Low | 1.35 SLU..... 8.0 DLU |
| | No Sounder | 1.35 SLU..... 8.0 DLU |
| Volume Level | Sounder High..... | 90+ dB(A) (For more information on sound output |
| (@ 1m anechoic, Dual Tone) | Sounder Low | 70+ dB(A) contact your supplier Ref 26-0747) |
| Flammability | | UL94-V2 |
| IP Rating | | IP 21C |
| Part Codes | No Sounder | 204 0003 |
| | With Sounder..... | 204 0001 |
| | With Sounder and Strobe..... | 204 0012 |

| | |
|----------------|-------------------|
| <u>Product</u> | <u>CPR Number</u> |
| 204-0003 | 0832-CPR-F0123 |
| 204-0001 | 0832-CPR-F0124 |
| 204-0012 | 0832-CPR-F0125 |

| | |
|---|--------------------|
|  0832 | |
| Fike Safety Technology Ltd Unit 31, Springvale Ind. Est. Torfaen, NP44 5BD 14 DoP-204-0001, DoP-204-0003, DoP-204-0012 | |
| EN54-3: 2001 +A1: 2002 +A2: 2006, EN54-5 : 2000 +A1: 2002, EN54-7: 2000 +A1: 2002 +A2: 2006, Sounder Technical Data: See 26-0747 | |
| 204-0001, 204-0003, 204-0012 Intended for use in the fire detection and fire alarm Systems in and around buildings | |
| Essential characteristics | Performance |
| Nominal activation conditions / Sensitivity, Response delay (response time) and Performance under fire conditions | Pass |
| Operational reliability | Pass |
| Tolerance to supply voltage | Pass |
| Durability of operational reliability and response delay, Temperature resistance | Pass |
| Durability of operational reliability, Vibration resistance | Pass |
| Durability of operational reliability, Humidity resistance | Pass |
| Durability of operational reliability, Corrosion resistance | Pass |
| Durability of operational reliability, Electrical stability | Pass |
| Durability of operational reliability, Resistance to ingress | Pass |

Technical Support

Contact your supplier for technical support on this product.

Due to the complexity and inherent importance of a life risk type system, training on this equipment is essential, and commissioning should only be carried out by competent persons. Fike cannot guarantee the operation of any equipment unless all documented instructions are complied with, without variation. This unit complies with the EMC directive.

Fike's policy is one of continual improvement and the right to change a specification at any time without notice is reserved. Whilst every care has been taken to ensure that the contents of this document are correct at time of publication, Fike shall be under no liability whatsoever in respect of such contents. E&OE.