

## TWINFLEX® WEATHERPROOF MCP

### DESCRIPTION

The Twinflex Weatherproof Manual Call Point (MCP) is a 'resettable' style MCP that has the option of being externally fitted if required. The weatherproof manual call point meets the IP65 standard for environmental protection and once operated the device latches into the alarm position and requires manually resetting via a special key. The device is fitted with a single colour red LED to indicate activation and End Of Line status.

This MCP is compatible with Fike's Twinflex range of control panels and may be installed on the same zone as the Multipoint detector/sounder and associated Twinflex devices. Its operating parameters are configured using a DIL switch on the rear of the device.



### SPECIFICATIONS

Dimensions:	Width x Height: 89mm x 89mm Depth: Standard inc base 71mm
Operating Temperature:	-10°C to +50°C
Voltage Range:	20 to 35V DC
IP Rating:	65
LED Indication:	Activated: 0.5 Second Interval End Of Line: 5 Second Interval
System Compatibility:	Twinflex: V1 onwards TwinflexPro: V1 onwards
Zone Current @ 24VDC:	Quiescent: 50uA Active: 16mA
SLU Rating:	3
DLU Rating:	16

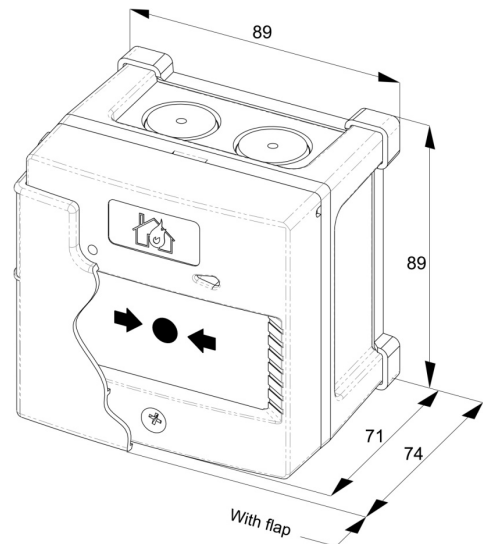

(All measurements shown are in millimetres)

### APPROVALS



331d/04

Approved to EN54 Part 11

### ORDERING INFORMATION

Fike P/N	Description
402 0007	Twinflex Weatherproof Manual Call Point - Red

### TERMINAL DEFINITIONS

RED (R)	(+) Zone In / Out	BLUE (B)	(-) Zone In / Out
E	Zone Screen In / Out		

### DIL SWITCH SETTINGS

		1
End Of Line	Enabled	ON
	Disabled	OFF

Form No. FST.2.16.01-1

*(This page is left blank intentionally)*

