

TWINFLEX[®]pro²



DATA SHEET

<http://www.fike.co.uk/resource-downloads/twinflex/>

DESCRIPTION

The TwinflexPro² panel is an intelligent 2-wire panel that utilises a conventional type cabling format. The system is classed as Analogue non-addressable due to the architecture used within the design. The devices communicate with the control panel using the Twinflex data protocol. The TwinflexPro² panel is available in 2,4 & 8 zone variants which support up to 32 Twinflex devices per circuit. The TwinflexPro² is able to recognise and separately identify between smoke detector, heat detector and a manual call point alarm. The panel also monitors each zone for detector head removal, device fault, End of line fault and open or short circuit fault. The panel provides two monitored outputs that may be configured as conventional sounder circuits, a volt free common fire relay and a volt free common fault relay. There are also two multifunction latching/non-latching inputs and one monitored input programmable with options such as Class-Change and Remote fire. The control panel also incorporates an integral power supply unit and requires 2 x 12V 3.3Ah batteries to provide up to 72 hour standby times (refer to Technical Data for further information).



The panel features a 500 event log, day/night mode, alarm confirmation and delay programming options that can be configured using the keypad or via PC driven OSP software. The TwinflexPro² panel is no longer only compatible with Fike's Twinflex devices, with the addition of our conventional zone card a 4 or 8 zone panel can now be configured to accept conventional devices on zones 5 to 8.

Unlike most conventional fire alarm systems, which require separate pairs of cables for detector zones and sounder circuits, the Twinflex system requires one 2-core screened cable for each zone to accommodate both detection devices and sounders when using Twinflex devices.

	2 Zone Panel	4 Zone Panel	8 Zone Panel
Dimensions (mm)		331 x 331 x 99	
Weight (excluding batteries)	2.25 kg	2.28 kg	2.36 kg
Construction	V0 rated ABS		
IP Rating	IP 30		
Cable Entry	13 x 20mm knockouts 1 x 50mm x 50mm pull out tab		
Cable type	2 core 1.5mm ² screened fire rated cable, 500m (max per zone)		
Detection zones	2 Max	4 Max	8 Max
Devices per zone	Up to 32 Devices dependant on Device Loading Units (DLUs) not exceeding the stated maximum loading.		
Device Protocol	TWINFLEX [®] V3 + TWINFLEX [®] pro		
Monitored sounder circuits	Up to 2 (250 mA)	Up to 2 (250 mA)	Up to 2 (200 mA)
Monitored relay circuits	Up to 2 (250 mA)	Up to 2 (250 mA)	Up to 2 (200 mA)
Relays on board	Common fire and common fault		
Operating standard	BS EN54-2 & 4		
Operating temperature	5°C to 40°C		
Mains Supply Range	230VAC, +10%, -15%, 50/60Hz		
Event Log:	500 Events		
Zone Labels:	12 Characters		

Fike P/N	Description
505-0002	TwinflexPro ² 2 Zone Control Panel
505-0004	TwinflexPro ² 4 Zone Control Panel
505-0008	TwinflexPro ² 8 Zone Control Panel

Approved to EN54 Part 2 & Part 4



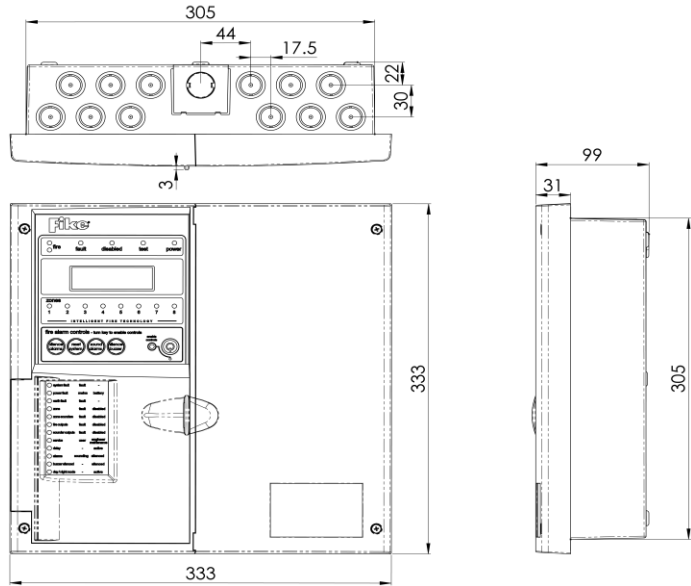

PANEL DIMENSIONS

(All measurements shown are in millimetres)

TERMINAL DEFINITIONS

Shaded items (Repeater panel) only available on 4 & 8 zone panels

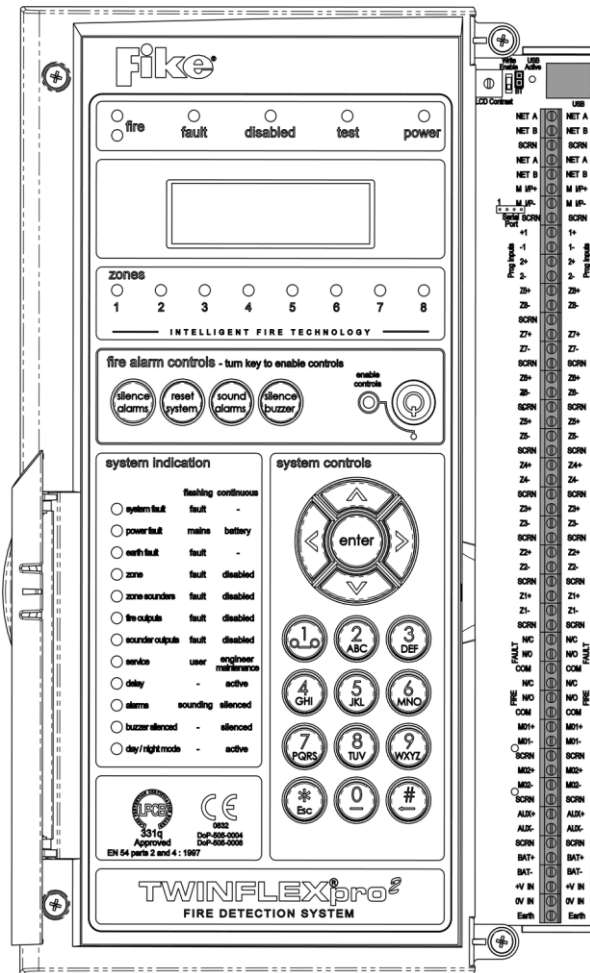

TERMINAL	DESCRIPTION
USB A-B	USB-B CONNECTION FOR PC LINK
NET A	Peripheral Bus Connections
NET B	Peripheral Bus Connections
SCRN	Field cable screen connection
NET A	Peripheral Bus Connections
NET B	Peripheral Bus Connections
M I/P 1 +	Monitored Input positive connection
M I/P 1 -	Monitored Input 0V connection
SCRN	Field cable screen connection
PROG I/P 1 +	Programmable Input positive connection
PROG I/P 1 -	Programmable Input 0V connection
PROG I/P 2 +	Programmable Input positive connection
PROG I/P 2 -	Programmable Input 0V connection
ZONES 1-8 +	Device zone positive connection
ZONES 1-8 -	Device zone 0V connection
SCRN	Field cable screen connection
FAULT RELAY N/C	Normally closed Volt free fault contact 1A 30V max
FAULT RELAY N/O	Normally open Volt free fault contact 1A 30V max
COM	Common fault contact
FIRE RELAY N/C	Normally closed Volt free fire contact 1A 30V max
FIRE RELAY N/O	Normally open Volt free fire contact 1A 30V max
COM	Common fire contact
MO 1 +	Monitored Output positive connection
MO 1 -	Monitored Output 0V connection
SCRN	Field cable screen connection
MO 2 +	Monitored Output positive connection
MO 2 -	Monitored Output 0V connection
SCRN	Field cable screen connection
AUX SUPPLY +	24-30V Aux Supply +V (250mA)
AUX SUPPLY -	24V Aux Supply 0V
SCRN	Field cable screen connection
BATTERY +	24V DC 3.3Ah Battery positive connection
BATTERY -	24V DC 3.3Ah Battery 0V connection
PSU +V IN	24V DC Input from Switch Mode PSU
PSU 0V IN	0V DC Input from Switch Mode PSU
Earth	Earth input from Switch Mode PSU

CONTACT INFORMATION

Fike Safety Technology Ltd

Unit 31 Springvale Industrial Estate,
Cwmbran
NP44 5BD

Tel: 01633 865 558 | Email: fstinfo@fike.com | www.fike.co.uk